

## 10 MAINTENANCE AND CLEANING

The following points have to be considered during the inspection:

- 1) All screws for installing the device or parts of the device have to be tightly connected and must not be corroded.
- 2) There must not be any deformations on the housing, color lenses, fixations and installation spots (ceiling, suspension, trussing).
- 3) Mechanically moved parts must not show any traces of wearing and must not rotate with unbalances.
- 4) The electric power supply cables must not show any damage, material fatigue or sediments.

Further instructions depending on the installation spot and usage have to be adhered by a skilled installer and any safety problems have to be removed.



### CAUTION

Disconnect from mains before starting maintenance operation.



In order to make the lights in good condition and extend the lifetime, we suggest a regular cleaning to the lights.

- 1) Clean the inside and outside lens each week to avoid the weakness of the lights due to accumulation of dust.
- 2) Clean the fan each week.
- 3) A detailed electric check by approved electrical engineer each three months, make sure that the circuit contacts are in good condition, prevent the poor contact of circuit from overheating.

We recommend a frequent cleaning of the device. Please use a moist, lint-free cloth. Never use alcohol solvents.

There are no serviceable parts inside the device. Please refer to the instructions under "Installation instructions".

Should you need any spare parts, please order genuine parts from your local dealer.

# STECHNICS

## LZOOM RGBW740

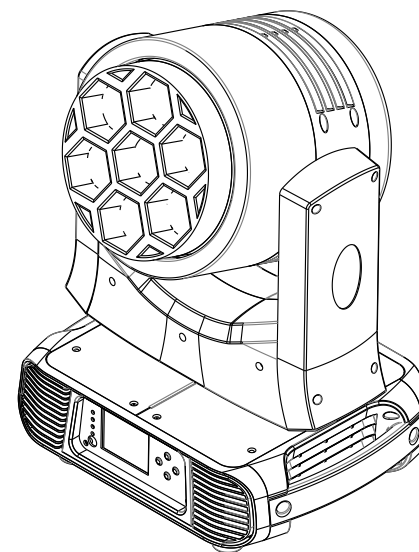

CE F IP20 LED  $\text{---}0.2\text{m}$   $t_a 40^\circ\text{C}$   $t_c 150^\circ\text{C}$

 МУЗЦЕНТР  
МУЗЫКАЛЬНОЕ ОБОРУДОВАНИЕ

<https://muzcentre.ru/>

## User Manual

KEEP THIS MANUAL FOR FUTURE NEEDS

# 1 SAFETY INSTRUCTIONS



## CAUTION

Becareful with your operations. With a dangerous voltage you can suffer a dangerous electric shock when touching wires!

This device has left the factory in perfect condition. In order to maintain this condition and to ensure a safe operation, it is absolutely necessary for the user to follow the safety instructions and warning notes written in this user manual.



## IMPORTANT

Damages caused by the disregard of this user manual are not subject to warranty. The dealer will not accept liability for any resulting defects or problems.

If the device has been exposed to temperature changes due to environmental changes, do not switch it on immediately. The arising condensation could damage the device. Leave the device switched off until it has reached room temperature.

This device falls under protection-class I. Therefore it is essential that the device be earthed.

The electric connection must carry out by qualified person.

The device shall only be used with rated voltage and frequency.

Make sure that the available voltage is not higher than stated at the end of this manual.

Make sure the power cord is never crimped or damaged by sharp edges. If this would be the case, replacement of the cable must be done by an authorized dealer.

Always disconnect from the mains, when the device is not in use or before cleaning it. Only handle the power cord by the plug. Never pull out the plug by tugging the power cord.

During initial start-up some smoke or smell may arise. This is a normal process and does not necessarily mean that the device is defective, it should decrease gradually.

Please don't project the beam onto combustible substances.

Fixtures cannot be installed on combustible substances, keep more than 50cm distance with wall for smooth air flow, so there should be no shelter for fans and ventilation for heat radiation.

If the external flexible cable or cord of this luminaire is damaged, it shall be exclusively replaced by the manufacturer or his service agent or a similar qualified person in order to avoid a hazard.

31	25			White in pixel 2	0..255	White in pixel 2 saturation control(0-100%)
32	26			Red in Pixel 3	0..255	Red in pixel 3 saturation control (0-100%)
33	27			Green in pixel 3	0..255	Green in pixel 3 saturation control(0-100%)
34	28			Blue in pixel 3	0..255	Blue in pixel 3 saturation control(0-100%)
35	29			White in pixel 3	0..255	White in pixel 3 saturation control(0-100%)
36	30			Red in Pixel 4	0..255	Red in pixel 4 saturation control (0-100%)
37	31			Green in pixel 4	0..255	Green in pixel 4 saturation control(0-100%)
38	32			Blue in pixel 4	0..255	Blue in pixel 4 saturation control(0-100%)
39	33			White in pixel 4	0..255	White in pixel 4 saturation control(0-100%)
40	34			Red in Pixel 5	0..255	White in pixel 5 saturation control (0-100%)
41	35			Green in pixel 5	0..255	Green in pixel 5 saturation control(0-100%)
42	36			Blue in pixel 5	0..255	Blue in pixel 5 saturation control(0-100%)
43	37			White in pixel 5	0..255	White in pixel 5 saturation control(0-100%)
44	38			Red in Pixel 6	0..255	White in pixel 6 saturation control (0-100%)
45	39			Green in pixel 6	0..255	Green in pixel 6 saturation control(0-100%)
46	40			Blue in pixel 6	0..255	Blue in pixel 6 saturation control(0-100%)
47	41			White in pixel 6	0..255	White in pixel 6 saturation control(0-100%)
48	42			Red in Pixel 7	0..255	White in pixel 7 saturation control (0-100%)
49	43			Green in pixel 7	0..255	Green in pixel 7 saturation control(0-100%)
50	44			Blue in pixel 7	0..255	Blue in pixel 7 saturation control(0-100%)
51	45			White in pixel 7	0..255	White in pixel 7 saturation control(0-100%)
52	46	20	14	Special Function	0..19	No function
					20..29	Dimmer Speed Fast
					30..39	Dimmer Speed Smooth
					40..49	Dimmer Curve Linear
					50..59	Dimmer Curve SQ
					60..69	Dimmer Curve Inv. SQ
					70..79	Dimmer Curve S.
					80-89	All motor reset
					90-94	Scan motor reset
					95-99	Focus motor reset
					100..119	Internal program 1
					120..139	Internal program 2
					140..159	Internal program 3
					160..179	Internal program 4
					180..199	Internal program 5
200..219	Internal program 6					
220..239	Internal program 7					
240..255	Function Null					

22	16	18	Dynamic Patterns	116..122	Dynamic Scene13
				123..129	Dynamic Scene14
				130..136	Dynamic Scene15
				137..143	Dynamic Scene16
				144..150	Dynamic Scene17
				151..157	Dynamic Scene18
				158..164	Dynamic Scene19
				165..171	Dynamic Scene20
				172..178	Dynamic Scene21
				179..185	Dynamic Scene22
				186..192	Dynamic Scene23
				193..199	Dynamic Scene24
				200..206	Dynamic Scene25
				207..213	Dynamic Scene26
				214..220	Dynamic Scene27
				221..227	Dynamic Scene28
				228..234	Dynamic Scene29
				235..241	Dynamic Scene30
				242..248	Dynamic Scene31
				249..255	Dynamic Scene32
			Static Patterns or Patterns Speed	000..007	Static scene1
				008..015	Static scene2
				016..023	Static scene3
				024..031	Static scene4
				032..039	Static scene5
				040..047	Static scene6
				048..055	Static scene7
				056..063	Static scene8
				064..071	Static scene9
				072..079	Static scene10
				080..087	Static scene11
				088..095	Static scene12
				096..103	Static scene13
				104..111	Static scene14
				112..119	Static scene15
				120..127	Static scene16
				128..135	Static scene17
				136..143	Static scene18
				144..151	Static scene19
				152..159	Static scene20
				160..167	Static scene21
				168..175	Static scene22
				176..183	Static scene23
				184..191	Static scene24
				192..199	Static scene25
				200..207	Static scene26
				208..215	Static scene27
				216..223	Static scene28
				224..231	Static scene29
				232..239	Static scene30
				240..247	Static scene31
				248..255	Static scene32
			Dynamic Patterns Speed (If channel 23 is in the interval 032 –	000..023	No function
				024..137	Forward speed from zero speed to fast speed
				138..141	Stop movement
				142..255	Reverse speed from zero speed to fast speed
24	18		Red in Pixel 1	0..255	Red in pixel 1 saturation control (0-100%)
25	19		Green in Pixel 1	0..255	Green in pixel 1 saturation control (0-100%)
26	20		Blue in Pixel 1	0..255	Blue in pixel 1 saturation control(0-100%)
27	21		White in pixel 1	0..255	White in pixel 1 saturation control(0-100%)
28	22		Red in pixel 2	0..255	Red in pixel 2 saturation control(0-100%)
29	23		Green in pixel 2	0..255	Green in pixel 2 saturation control(0-100%)
30	24		Blue in pixel 2	0..255	Blue in pixel 2 saturation control(0-100%)

## 2 UNPACKING

Thank you for choosing our LZOOM RGBW740. For your own safety, please read this manual before installing the device. This manual covers the important information on installation and applications. Please install and operate the fixture with following instructions. Meanwhile, please keep this manual well for future needs.

The LZOOM RGBW740 is made of a new type of high temperature strength of engineering plastics and cast aluminum casing with nice outlook. The fixture is designed and manufactured strictly following CE standards, complying with international standard DMX512 protocol. It's available independently controlled and linkable with each other for operation. And it is applicable for large-scale live performances, theater, studio, nightclubs and discos.

The LZOOM RGBW740 adopts 7PCS 4-IN-1 40W LEDs which features high brightness and stability. Please carefully unpack it when you receive the fixture and check whether it is damaged during the transportation. And please check whether the following items are included inside the box:

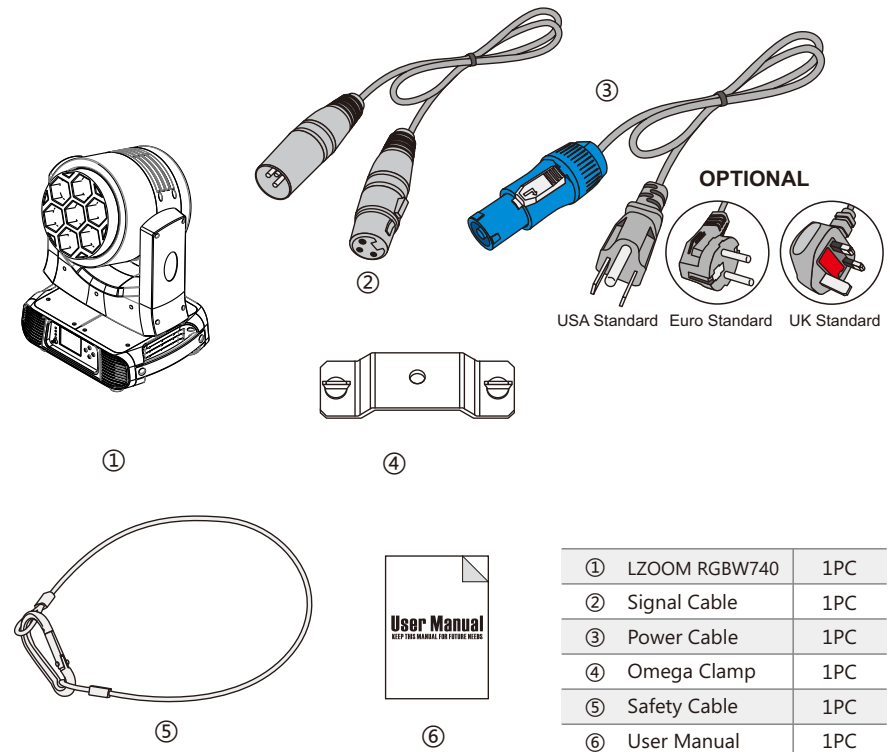

①	LZOOM RGBW740	1PC
②	Signal Cable	1PC
③	Power Cable	1PC
④	Omega Clamp	1PC
⑤	Safety Cable	1PC
⑥	User Manual	1PC

# 3 FEATURES & SPECIFICATIONS

## Features

- 7\*40W OSRAM 4-IN-1 RGBW LEDs
- 50,000 hours lifespan and low power consumption
- Pixel mapping capability with each LEDs controllable individually
- Specific optic lens of highly efficient elements integrated with glass tube
- Fast, smooth and quiet motorized zoom with 5° -62° range
- Even, soft edge and pure color mixing coverage
- Flicker free sources management
- 8/16 Bit smooth, fast and precise PAN/TILT movement
- 540° PAN and 270° TILT movement
- PAN/TILT reversible advantage
- PAN/TILT calibration available
- Scan position memory, auto reposition after unexpected movement
- 0-100% Smooth linear LED dimmer
- Fine dimmer available
- 5 Dimmer modes (default, standard, stage, TV, theatre) and 4 dimmer curves (default, linear, square law, inv SQ law)
- Different pre-programming virtual colors and linear color temperature adjustment
- Linear color temperature adjustment from 2800K to 8000K
- Virtual tungsten lamp simulation effect from 2800K-3200K
- Different pre-programming dynamic patterns with variable speed and bi-directional rotation
- Different pre-programming static patterns
- Different foreground color options and linear color temperature adjustments for dynamic/static PATTERNS, with 0-100% linear dimmer
- Different background color options and linear color temperature adjustments for dynamic/static PATTERNS, with 0-100% linear dimmer
- Different built-in default programs for easy operation
- 10 Kinds of variable speed strobe effect with 1-25 flashes per second
- 14/20/46/52 CH DMX channel modes (USITT DMX-512)
- DMX512, master-slave, and sound activated controllable or auto operation
- DMX recorder and edit function integrated
- Sound control with sensitivity adjustment
- RDM available (Remote Device Management)
- Art-NET as optional
- Wireless Solution' s wireless receiver system built-in as optional
- 2.4" TFT LCD display (320\*240pix) with 4 control buttons and battery back-up for menu preset
- 180° Reversible for LCD display
- LCD display switch-off automatically after 60 seconds
- DMX signal monitoring indicator available
- Software up-datable through DMX connectors
- Efficient low noise self adjusting fan cooling system
- Constant temperature readout and management function

18	12	14	Foreground Color for Patterns	1..13	Red
				14..27	Green
				28..41	Blue
				42..55	White
				56..69	Red+White
				70..83	Green+White
				84..97	Blue+White
				98..111	Green+Blue
				112..125	Red+Blue
				126..139	Red+Green
				140..153	Green+Blue+White
				154..167	Red+Blue+White
				168..181	Red+Green+White
				182..195	Red+Blue+Green+White
				196..202	2700K
203..209	3200K				
210..216	3500K				
217..223	5000K				
224..230	5500K				
231..237	6000K				
238..244	6500K				
245..251	7000K				
252..255	8000K				
19	13	15	Foreground Dimmer	000..255	Foreground dimmer 0 - 100%.
20	14	16	Background Color for Patterns	0..0	No Function
				1..13	Red
				14..27	Green
				28..41	Blue
				42..55	White
				56..69	Red+White
				70..83	Green+White
				84..97	Blue+White
				98..111	Green+Blue
				112..125	Red+Blue
				126..139	Red+Green
				140..153	Green+Blue+White
				154..167	Red+Blue+White
				168..181	Red+Green+White
				182..195	Red+Blue+Green+White
196..202	2700K				
203..209	3200K				
210..216	3500K				
217..223	5000K				
224..230	5500K				
231..237	6000K				
238..244	6500K				
245..251	7000K				
252..255	8000K				
21	15	17	Background Dimmer	000..255	Background dimmer 0 - 100%.
				000..015	No function and 24th channel behind pixel can control
				016..031	24th Channel display static scene
				032..038	Dynamic Scene1
				039..045	Dynamic Scene2
				046..052	Dynamic Scene3
				053..59	Dynamic Scene4
				060..066	Dynamic Scene5
				067..073	Dynamic Scene6
				074..080	Dynamic Scene7
				081..087	Dynamic Scene8
				088..094	Dynamic Scene9
				095..101	Dynamic Scene10
102..108	Dynamic Scene11				
109..115	Dynamic Scene12				

# 9 DMX CHANNELS

Mode/Channel				Function	Value	Function
52	46	20	14			
1	1	1	1	PAN	0..255	PAN Movement
2	2	2	2	PAN Fine	0..255	Fine control of Pan movement
3	3	3	3	TILT	0..255	Tilt Movement
4	4	4	4	TILT Fine	0..255	Fine control of Tilt movement
5	5	5	5	Speed PAN/TILT	0..225	max to min speed
					226..235	blackout by movement
					236..255	no function
6	6	6	6	Dimmer	0..255	Dimmer 0%...100%
7	7			Dimmer Fine	0..255	Fine control of dimmer
8	8	7	7	Sutter	0..31	Shutter closed
					32..63	shutter open
					64..95	Strobe effect slow to fast
					96..127	shutter open
					128..159	Pulse-effect in sequences slow to fast
					160..191	shutter open
					192..255	shutter open
9		8	8	Red	0..255	0-100% Red dimmer from dark to bright
10		9	9	Green	0..255	0-100% Green dimmer from dark to bright
11		10	10	Blue	0..255	0-100% Blue dimmer from dark to bright
12		11	11	White	0..255	0-100% White dimmer from dark to bright
13	9	12	12	Zoom	0..255	In(near) to out(far)
14	10			Zoom Fine	0..255	Fine control of zoom
15	11	13	13	Color Macro	000-009	Open
					010-017	Color1
					018-024	Color2
					025-032	Color3
					033-039	Color4
					040-047	Color5
					048-054	Color6
					055-061	Color7
					062-069	Color8
					070-076	Color9
					077-084	Color10
					085-091	Color11
					092-099	Color12
					100-106	Color13
					107-113	Color14
					114-121	Color15
					122-128	Color16
					129-136	Color17
					137-143	Color18
					144-151	Color19
					152-158	Color20
					159-165	Color21
					166-173	Color22
					174-180	Color23
					181-188	Color24
					189-195	Color25
					196-203	Color26
					204-210	Color27
					211-217	Color28
					218-225	Color29
					226-232	Color30
					233-240	Color31
					241-247	Color32
248-255	Color33					
16					0	No Function
					001-255	8000K-3200K
					0..15	No Function
17				Visual Tungsten	16..255	3200K-2800K
					0..0	No Function

- Over heat protection management
- Powercon IN/ OUT with power switch and fuse
- 3-Pin XLR DMX connectors IN/OUT
- IP20 protection rating
- -20~45° C ambient temperature
- 2\*1/4 turn fastening Omega Clamps (Adaptable vertically and horizontally)
- 1\*Safety attachment point
- CE (EMC/LVD) and RoHS certified

## Specifications

Input Voltage: AC100-240V 50/60Hz

LED Quantities: 7\*40W OSRAM 4-IN-1 RGBW LEDs

Control Signal: RDM, DMX512, master-slave and sound activated or auto operation

Control Channel: 14/20/46/52 DMX channel modes

Power Consumption: 350W

Dimensions: 279(D)\*421(W)\*411(H)mm

Packing Dimensions: 280(D)\*490(W)\*560(H)mm

Net Weight: 10kg

Gross Weight: 13kg

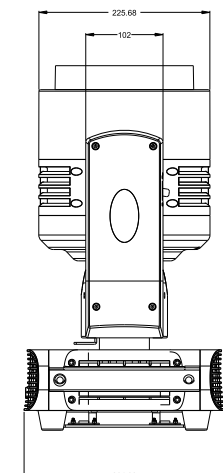
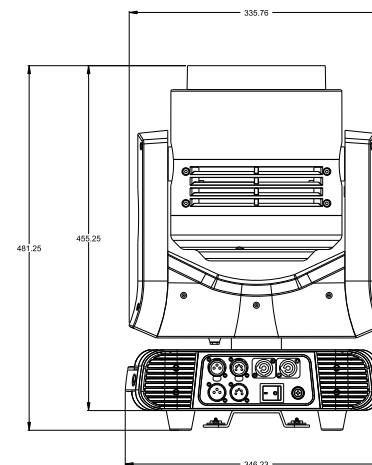

## 4 PHOTOMETRIC DATA

### Photometric Beam Angle Data<sup>8</sup> ~62° Beam Angle LUX × 0.0929=FC

<b>R</b>	654 / 7040 96 / 1037	92 / 990 7 / 77	32 / 341 2 / 25	16 / 177 1 / 12	
<b>G</b>	880 / 9460 130 / 1386	131 / 1408 17 / 184	45 / 500 3 / 36	23 / 250 1 / 16	
<b>B</b>	920 / 9900 134 / 1448	143 / 1540 10 / 110	50 / 536 3 / 40	25 / 270 1 / 19	
<b>W</b>	1206 / 12980 170 / 1830	180 / 1941 13 / 144	70 / 740 5 / 51	387 / 352 2 / 26	
<b>RGBW</b>	3198 / 34430 350 / 3756	522 / 5624 470 / 426	201 / 2167 14 / 154	101 / 1100 7 / 80	(8°) (62°) (FC/LUX)

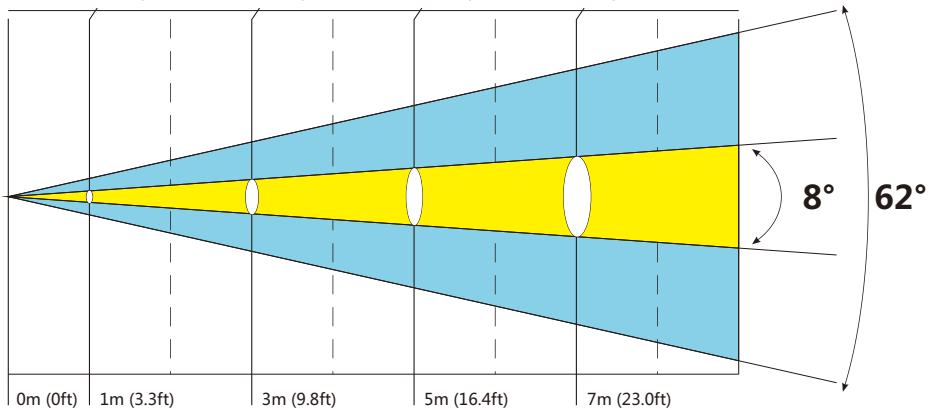

## 5 OPERATION INSTRUCTIONS

- The LZOOM RGBW740 is for wash effect for on-site decoration purpose.
- Don't turn on the fixture if it's been through severe temperature difference like after transportation because it might damage the light due to the environment changes. So make sure to operate the fixture until it is in normal temperature.
- This light should be keep away from strong shaking during any transportation or movement.
- Don't pull up the light by only the head, or it might cause damages to the mechanical parts.
- Don't expose the fixture in overheat, moisture or environment with too much dust when installing it. And don't lay any power cables on the floor. Or it might cause electronic shock to the people.
- Make sure the installation place is in good safety condition before installing the fixture.

Display Setting	Display Inverse	No	
		Yes	
	Backlight Auto Off	No	
		Yes	
	Display Intensity	0-10	
Temperature Unit		°C	
		°F	
Language		English	
		Chinese	
Fixture Test	Auto Test		
	Manual Test		
Fixture Information	Fixture use time		
	Fixture Temperature		
	Firmware Version		
Reset Functions	Pan/Tilt	No	
		Yes	
	Zoom/Rotation	No	
		Yes	
All	No		
	Yes		
Special Functions	Factory Default	No	
		Yes	

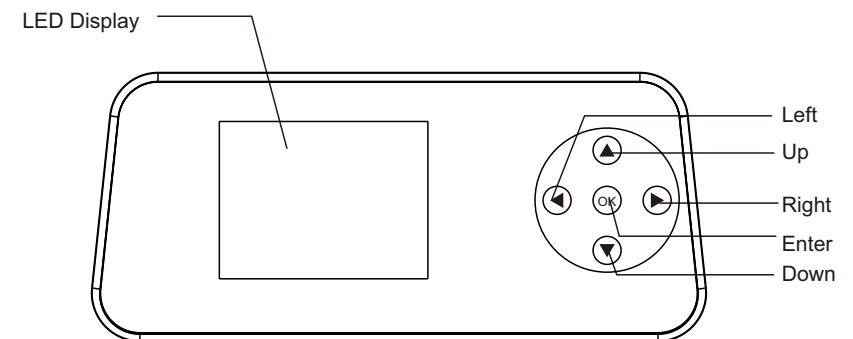

## 8 MENU OPERATIONS

MENU	DMX Functions	Dmx Addr	001-512		
		DMX Channel Mode	Mode1(14)		
			Mode2(20)		
			Mode3(46)		
			Mode4(52)		
		DMX State	BlackOut		
			M/S Mode		
			Hold		
		Connect to	XLR Priority		
			Wireless Priority		
			Wireless Only		
			ArtNet Only		
		DMX Retransmit	XLR Only		
	Yes				
	Un-Link Wireless	No			
		Yes			
	Ethernet IP Settings	No			
		IP Address			
	ArtNet Settings	Subnet Mask			
Net		000-255			
View DMX Value					
Show Setting	Auto Mode	Auto 1			
		Auto 2			
		Auto 3			
		Auto 4			
Sound Active	Yes				
	No				
Mic Sensitivity	000-100				
Fixture Setting	Pan Inverse	No			
		Yes			
	Tilt Inverse	No			
		Yes			
	P/T Feedback	No			
		Yes			
	White Balance	Red	125-255		
		Green	125-255		
		Blue	125-255		
		White	125-255		
	Dimmer Curve	Linear			
		Square Law			
Inverse Squ.					
S-Curve					
Dimmer Speed	Fast				
	Smooth				

- Make sure to put the safety chain and check whether the screws are screwed properly when installing the fixture.
- Make sure the lens are in good condition. It's recommended to replace the units if there are any damages or severe scratch.
- Make sure the fixture is operated by qualified personnel who knows the fixture before using.
- Keep the original packages if any second shipment is needed.
- Don't try to change the fixtures without any instruction by the manufacturer or the appointed repairing agencies.
- It is not in warranty range if there are any malfunctions from not following the user manual to operate or any illegal operation, like shock short circuit, electronic shock, lamp broke, etc.

## 6 INSTALLATIONS

**Cautions:** For added protection mount the fixtures in areas outside walking paths, seating areas, or in areas were the fixture might be reached by unauthorized personnel.

Before mounting the fixture to any surface, make sure that the installation area can hold a minimum point load of 10 times the device's weight.

Fixture installation must always be secured with a secondary safety attachment, such as an appropriate safety cable.

Never stand directly below the device when mounting, removing, or servicing the fixture.

from a ceiling, or set on a flat level surface (see illustration below). Be sure this fixture is kept at least 0.5m (1.5 ft) away from any flammable materials (decoration etc.).

Always use and install the supplied safety cable as a safety measure to prevent accidental damage and/or injury in the event the clamp fails.

**Mounting points:** Overhead mounting requires extensive experience, including amongst others calculating working load limits, a fine knowledge of the installation material being used, and periodic safety inspection of all installation material and the fixture. If you lack these qualifications, do not attempt the installation yourself. Improper installation can result in bodily injury.

Be sure to complete all rigging and installation procedures before connecting the main power cord to the appropriate wall outlet.

**Clamp Mounting:** The LZOOM RGBW740 provides a unique mounting bracket assembly that integrates the bottom of the base, and the safety cable rigging point in one unit (see the illustration below). When mounting this fixture to truss be sure to secure an appropriately rated clamp to the included omega bracket using a M10 screw fitted through the center hole of the "omega bracket". As an added safety measure be sure to attached at least one properly rated safety cable to the fixture using on of the safety cable rigging point integrated in the base assembly.

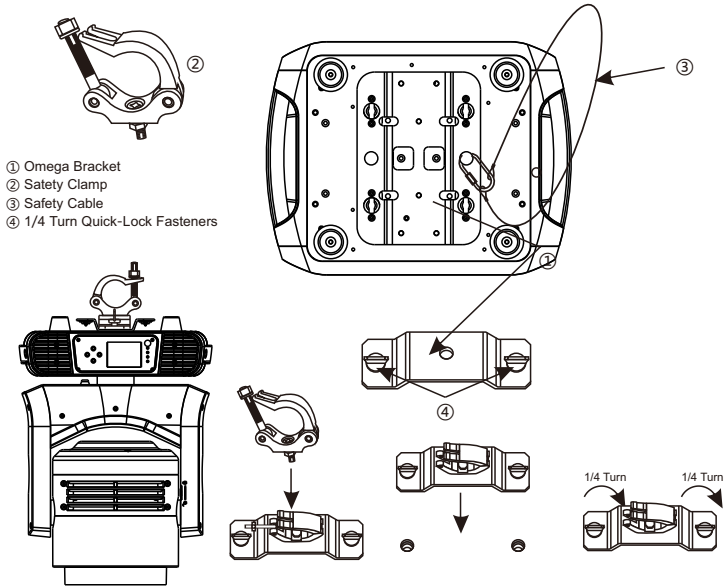

Regardless of the rigging option you choose for your LZOOM RGBW740 always be sure to secure your fixture with a safety cable. The fixture provides a built-in rigging point for a safety cable on the hanging bracket as illustrated above. Be sure to only use the designated rigging point for the safety cable and never secure a safety cable to a carrying handle.

## 7 DMX-512 CONTROL CONNECTIONS

Connect the provided XLR cable to the female 3-pin XLR output of your controller and the other side to the male 3-pin XLR input of the moving head. You can chain multiple

Moving head together through serial linking. The cable needed should be two core, screened cable with XLR input and output connectors. Please refer to the diagram below.

DMX-512 connection with DMX terminator

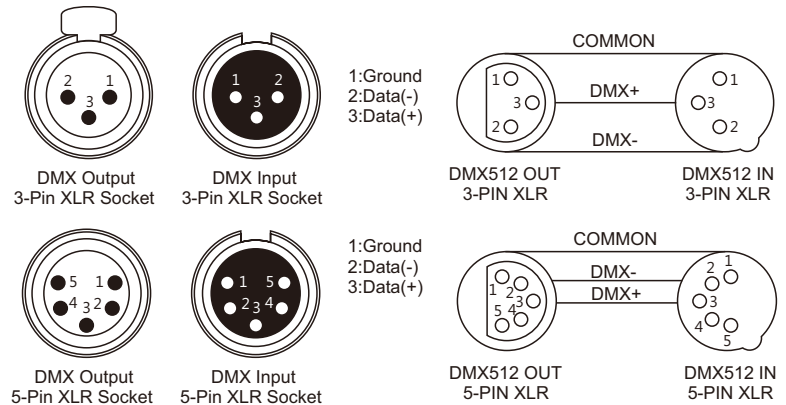
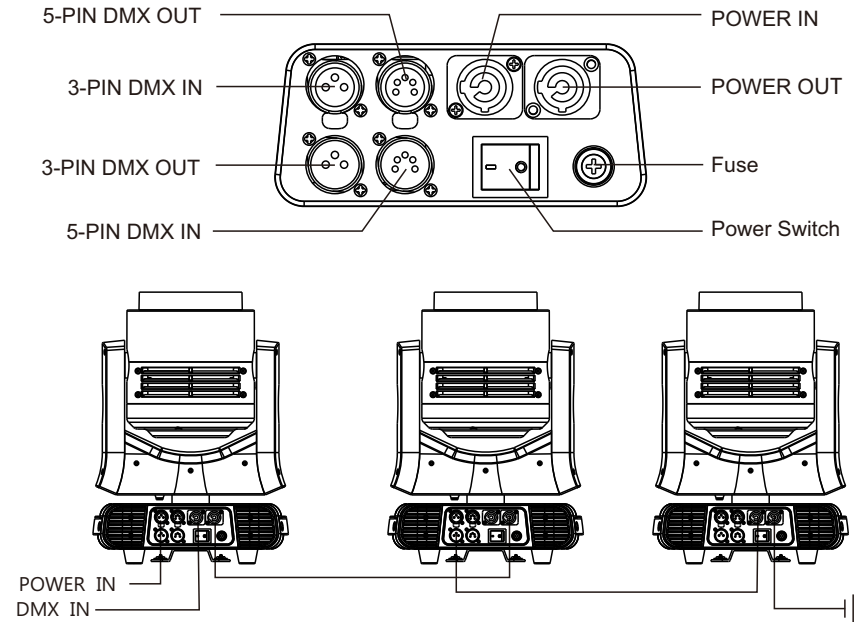

For installations where the DMX cable has to run a long distance or is in an electrically noisy environment, such as in a discotheque, it is recommended to use a DMX terminator. This helps in preventing corruption of the digital control signal by electrical noise. The DMX terminator is simply an XLR plug with a 120 Ω resistor connected between pins 2 and 3, which is then plugged into the output XLR socket of the last fixture in the chain. Please see illustrations below.

